

MD-DIN

Bent Axis Motor



DIN Mounting Flange, Flange, 4 Bolt, 12cc to 130cc

DIN Mounting Flange, High Pressure Bent Axis Piston Motors. Reversible Direction of Rotation.
Displacement Range starting at; 12cc, 18cc, 25cc, 32cc, 40cc, 50cc, 63cc, 80cc, 108cc, 130cc
400/450 Bar, High Pressure, High Rotational Speed, Slim Design, High Efficiency.



Ordering Code of MD Motors

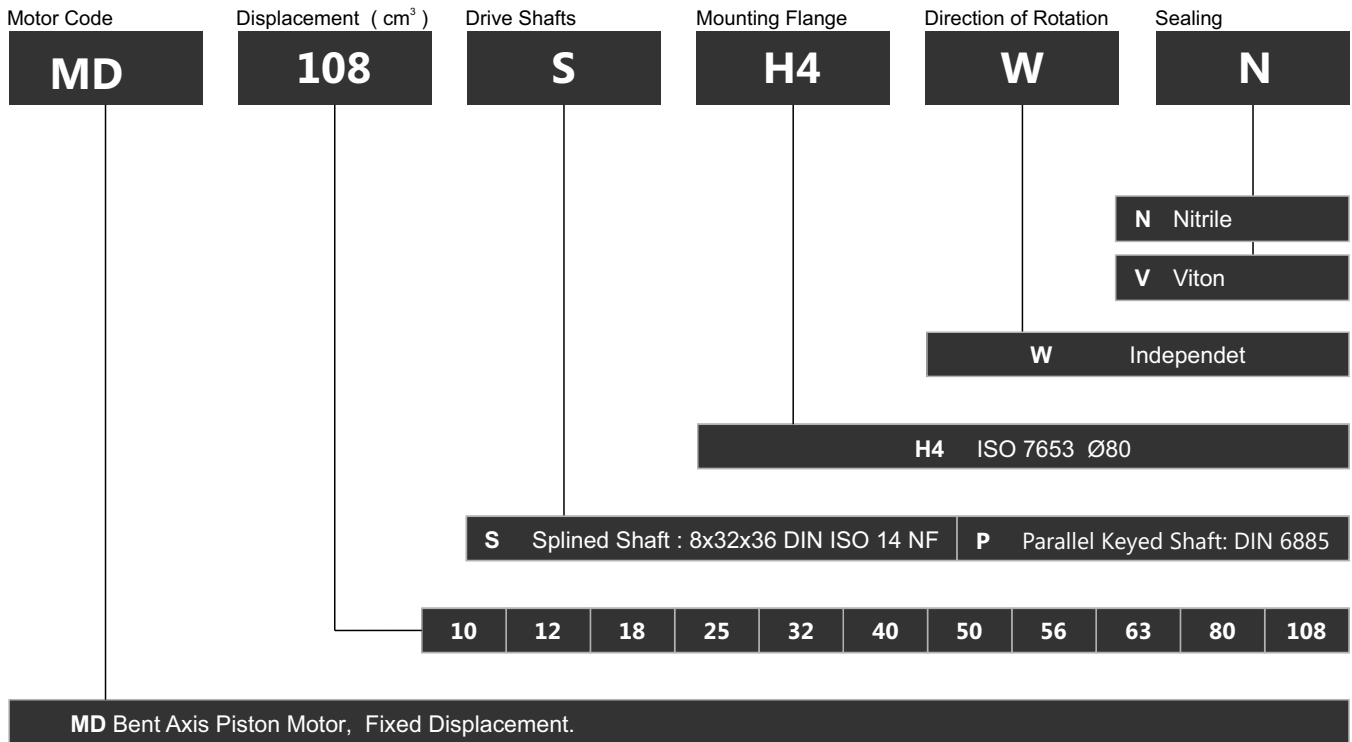

Formulas

Pump Output Flow	GPM	$GPM = (\text{Speed (rpm)} \times \text{disp. (cu. in.)}) / 231$	$GPM = (n \times d) / 231$
Pump Input Horsepower	HP	$HP = GPM \times \text{Pressure (psi)} / 1714 \times \text{Efficiency}$	$HP = (Q \times P) / 1714 \times E$
Pump Efficiency	E	Overall Efficiency = Output HP / Input HP	$E_{\text{Overall}} = \text{HP}_{\text{Out}} / \text{HP}_{\text{In}} \times 100$
		Overall Efficiency = Volumetric Eff. × Mechanical Eff.	$E_{\text{Overall}} = \text{EffVol.} \times \text{EffMech.}$
Pump Volumetric Efficiency	E	Volumetric Efficiency = Actual Flow Rate Output (GPM) / Theoretical Flow Rate Output (GPM) × 100	$\text{EffVol.} = \text{Q}_{\text{Act.}} / \text{Q}_{\text{Theo.}} \times 100$
Pump Mechanical Efficiency	E	Mechanical Efficiency = Theoretical Torque to Drive / Actual Torque to Drive × 100	$\text{EffMech} = \text{T}_{\text{Theo.}} / \text{T}_{\text{Act.}} \times 100$
Pump Displacement	CIPR	$\text{Displcmnt (In.}^3 \text{ / rev.)} = \text{Flow Rate (GPM)} \times 231 / \text{Pump RPM}$	$\text{CIPR} = \text{GPM} \times 231 / \text{RPM}$
Pump Torque	T	Torque = Horsepower × 63025 / RPM	$T = 63025 \times \text{HP} / \text{RPM}$
		Torque = Pressure (PSIG) × Pump Displacement (CIPR) / 2π	$T = P \times \text{CIPR} / 6.28$

- Horsepower for driving a pump** : For every 1 hp of drive, the equivalent of 1 gpm @ 1500 psi can be produced.
- Horsepower for idling a pump** : To idle a pump when it is unloaded will require about 5% of it's full rated power
- Wattage for heating hydraulic oil** : Each watt will raise the temperature of 1 gallon of oil by 1° F. per hour.
- Flow velocity in hydraulic lines** : Pump suction lines 2 to 4 feet per second, pressure lines up to 500 psi - 10 to 15 ft./sec., pressure lines 500 to 3000 psi - 15 to 20 ft./sec.; all oil lines in air-over-oil systems; 4 ft./sec.

Technical Data II

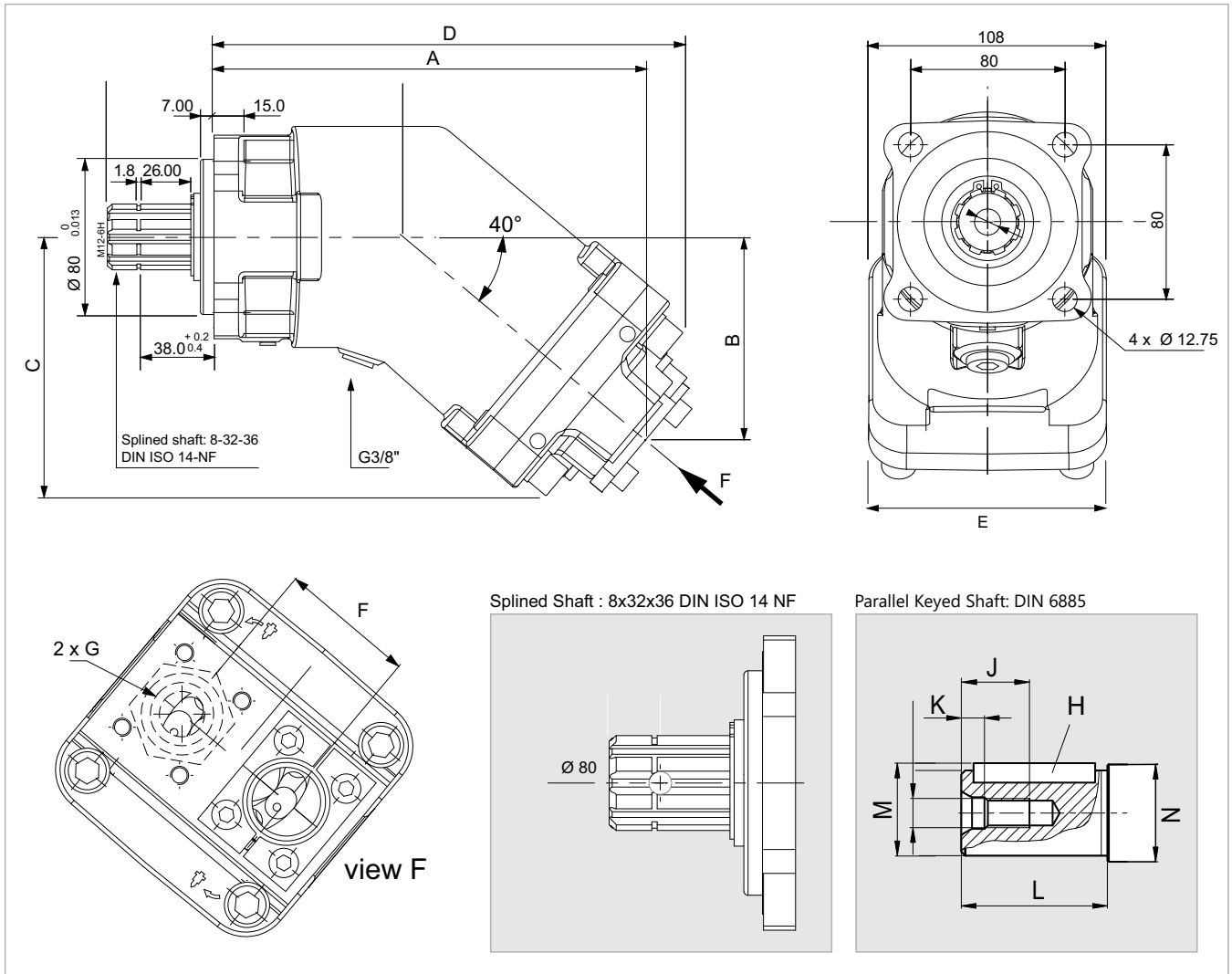

	10	12	18	25	32	40	50	56	63	80	108
cc	10,00	12,00	18,00	25,00	32,00	40,20	50,00	56,40	63,00	80,00	108,4
A	170,0	170,0	170,0	170,0	177,0	177,0	188,0	188,0	188,0	215,0	215,0
B	71,0	71,0	71,0	71,0	76,0	76,0	86,0	86,0	86,0	98,0	98,0
C	103,0	103,0	103,0	103,0	108,0	108,0	118,0	118,0	118,0	132,0	132,0
D	197,0	197,0	197,0	197,0	202,0	202,0	214,0	214,0	214,0	240,0	240,0
E	107,5	107,5	107,5	107,5	107,5	107,5	107,5	107,5	107,5	122,5	122,5
F	54,0	54,0	54,0	54,0	54,0	54,0	54,0	54,0	54,0	60,0	60,0
G	G 3/4"	G 3/4"	G 3/4"	G 3/4"	G 3/4"	G 3/4"	G 3/4"	G 3/4"	G 3/4"	G 1"	G 1"

H	6	6	8	8	10	10	10	10	10	12	12
J	16	16	22	22	28	28	28	28	28	28	28
K	5	5	7,5	7,5	9,5	9,5	9,5	9,5	9,5	9,5	9,5
L	40	40	50	50	60	60	60	60	60	70	80
M	22,5	22,5	33	33	38	38	38	38	38	38	43
N	Ø 28	Ø 28	Ø 35	Ø 35	Ø 35	Ø 35	Ø 40	Ø 40	Ø 40	Ø 45	Ø 50

MD 10

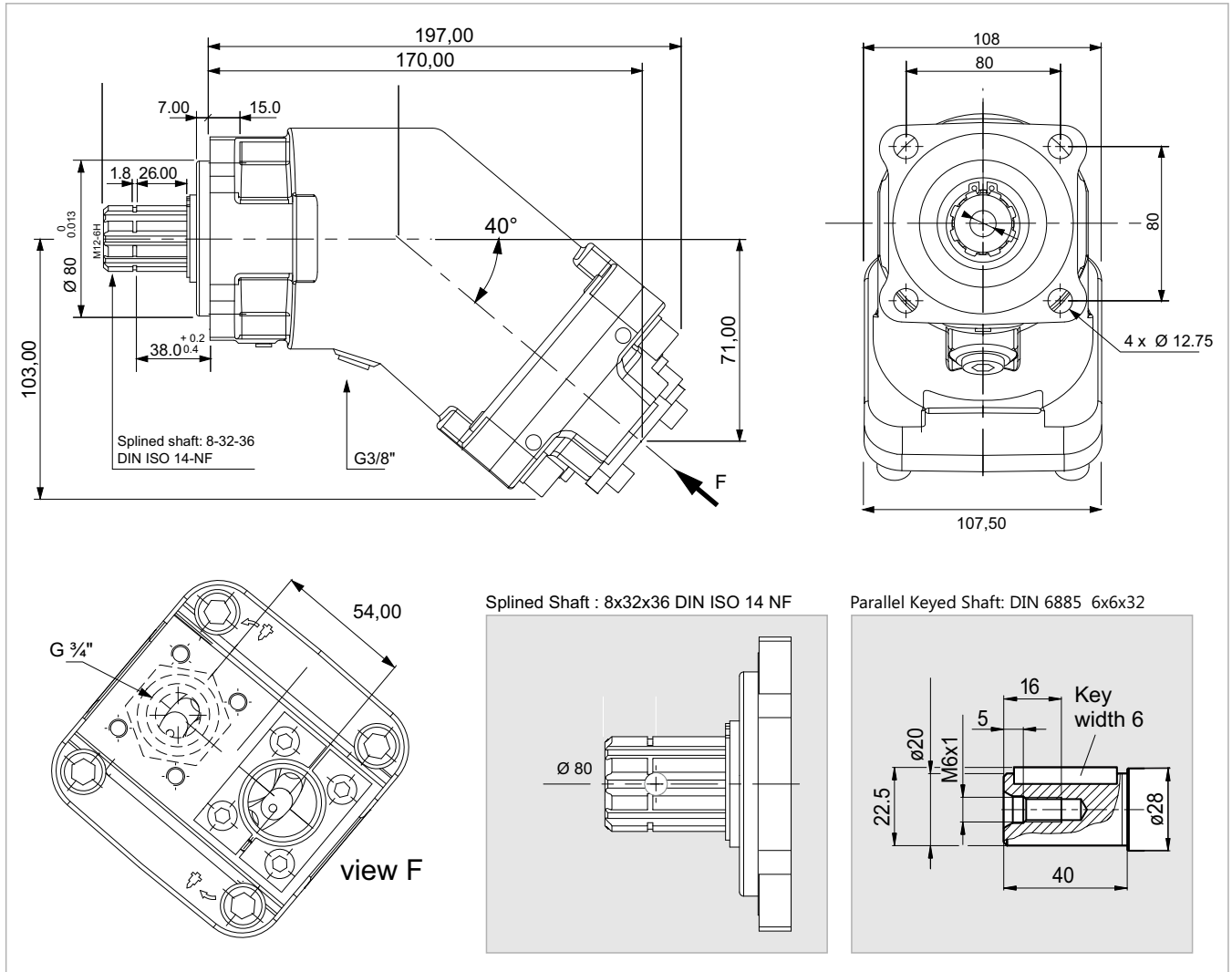

x 1000 rpm	10,00 cc
x 1500 rpm	15,00 cc
Max. Continuous Pump Speed	8000 rpm
Max. Intermittent Pump Speed	8800 rpm
Max. Continuous Pressure	400 bar
Max. Peak Pressure	450 bar
Torque bar	0.17 m.N/bar
Torque at 350 bar	64 m.N
Weight without accessories	9,00 kg
Weight with accessories	9,50 kg
Max. Motor Temperature	-25°
Min. Motor Temperature	110°

MD 12

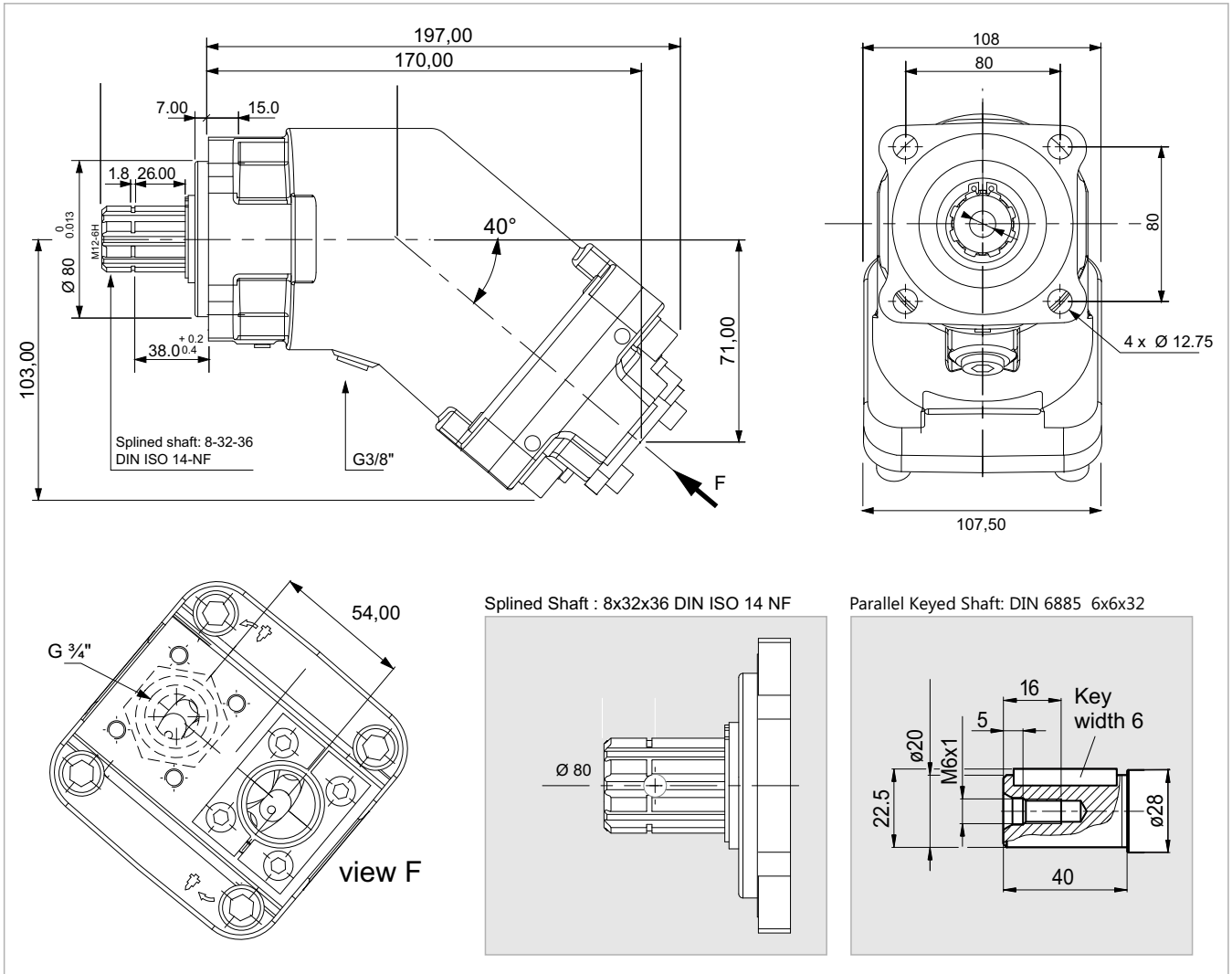

x 1000 rpm	12,00 cc
x 1500 rpm	18,00 cc
Max. Continuous Pump Speed	8000 rpm
Max. Intermittent Pump Speed	8800 rpm
Max. Continuous Pressure	400 bar
Max. Peak Pressure	450 bar
Torque bar	0.18 m.N/bar
Torque at 350 bar	66 m.N
Weight without accessories	9,00 kg
Weight with accessories	9,50 kg
Max. Motor Temperature	-25°
Min. Motor Temperature	110°

MD 18

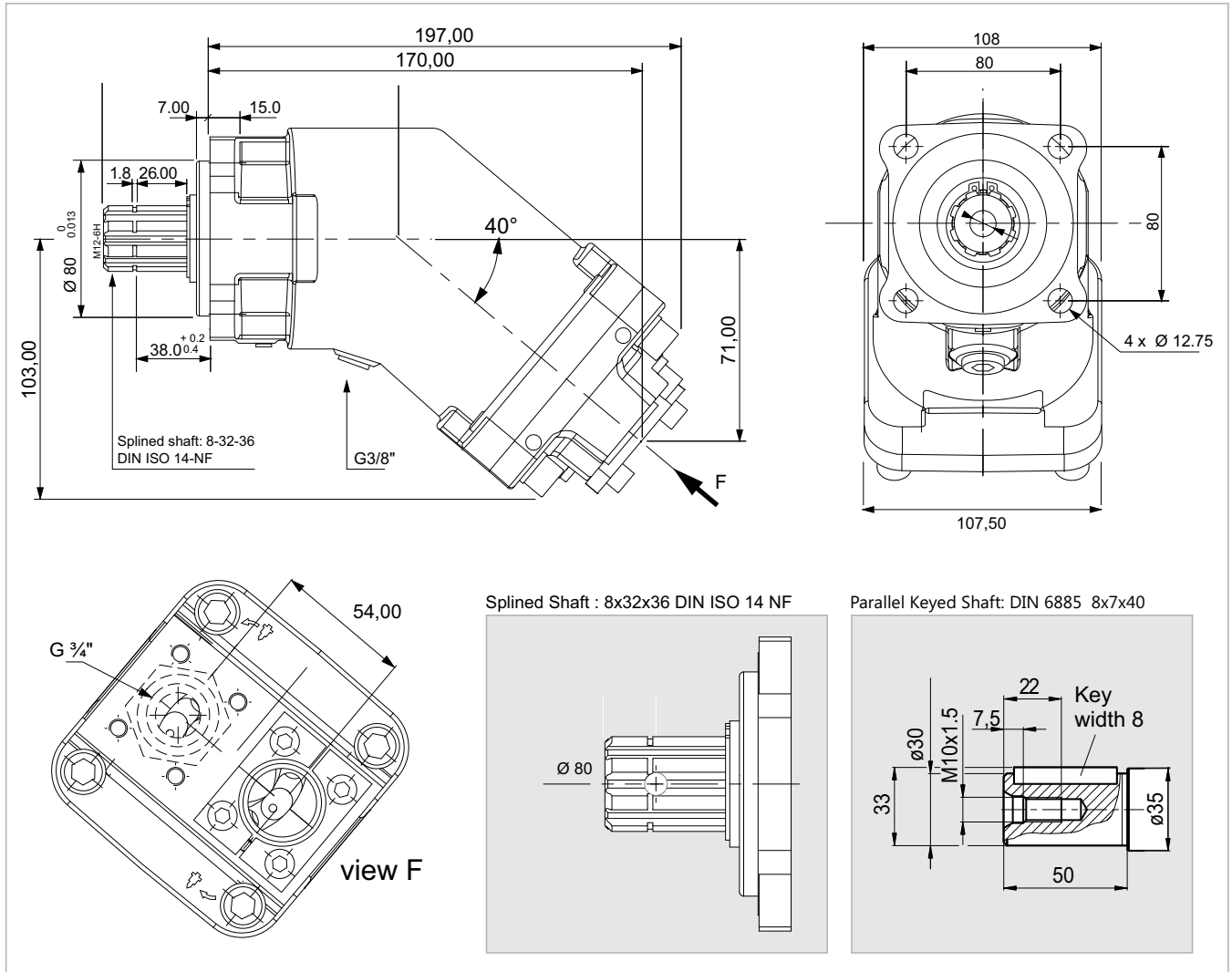

x 1000 rpm	18,00 cc
x 1500 rpm	27,00 cc
Max. Continuous Pump Speed	8000 rpm
Max. Intermittent Pump Speed	8800 rpm
Max. Continuous Pressure	400 bar
Max. Peak Pressure	450 bar
Torque bar	0.28 m.N/bar
Torque at 350 bar	98 m.N
Weight without accessories	10,00 kg
Weight with accessories	10,50 kg
Max. Motor Temperature	-25°
Min. Motor Temperature	110°

MD 25

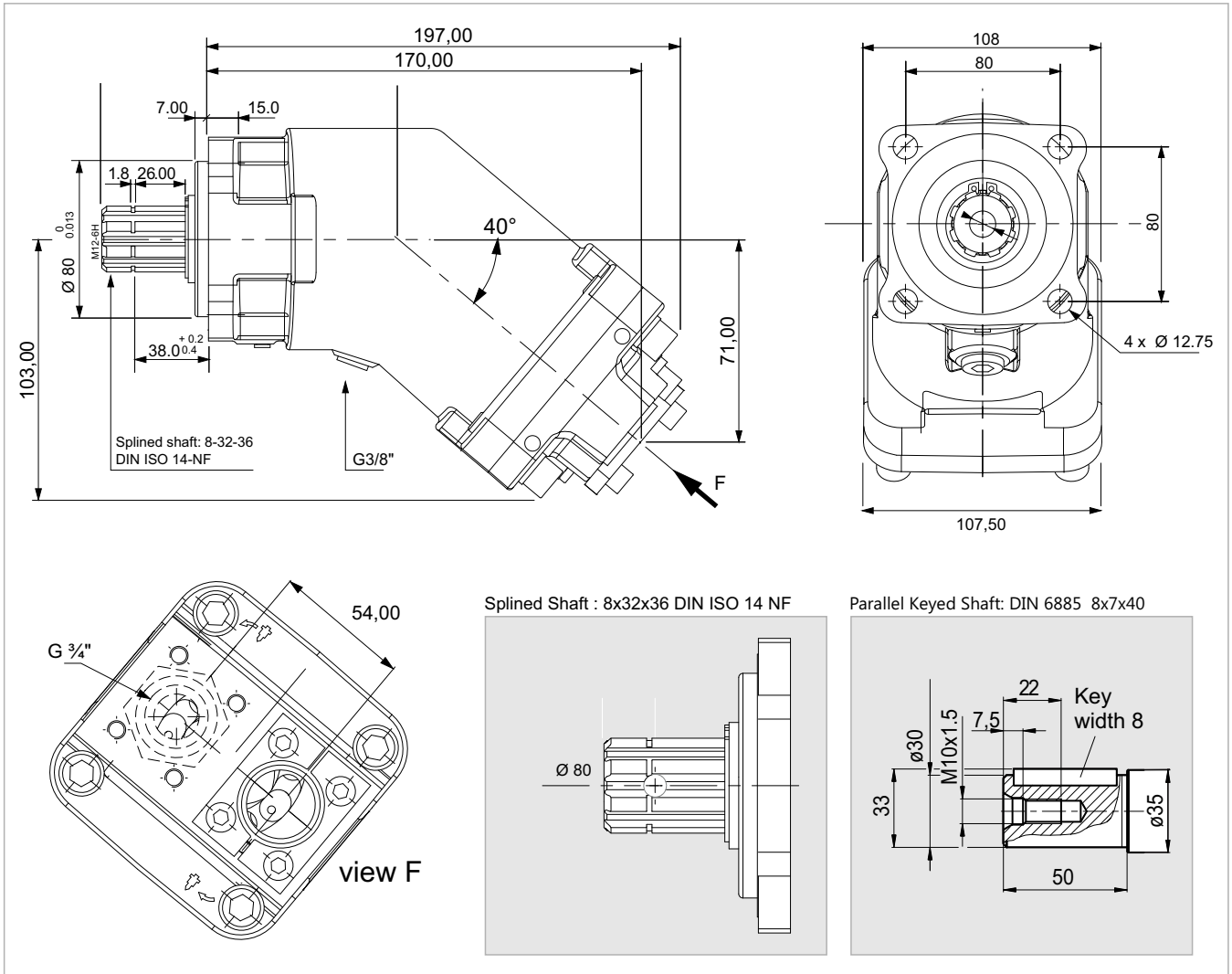

x 1000 rpm	25,00 cc
x 1500 rpm	37,50 cc
Max. Continuous Pump Speed	6250 rpm
Max. Intermittent Pump Speed	6800 rpm
Max. Continuous Pressure	400 bar
Max. Peak Pressure	450 bar
Torque bar	0.40 m.N/bar
Torque at 350 bar	140 m.N
Weight without accessories	10,00 kg
Weight with accessories	10,50 kg
Max. Motor Temperature	-25°
Min. Motor Temperature	110°

MD 32

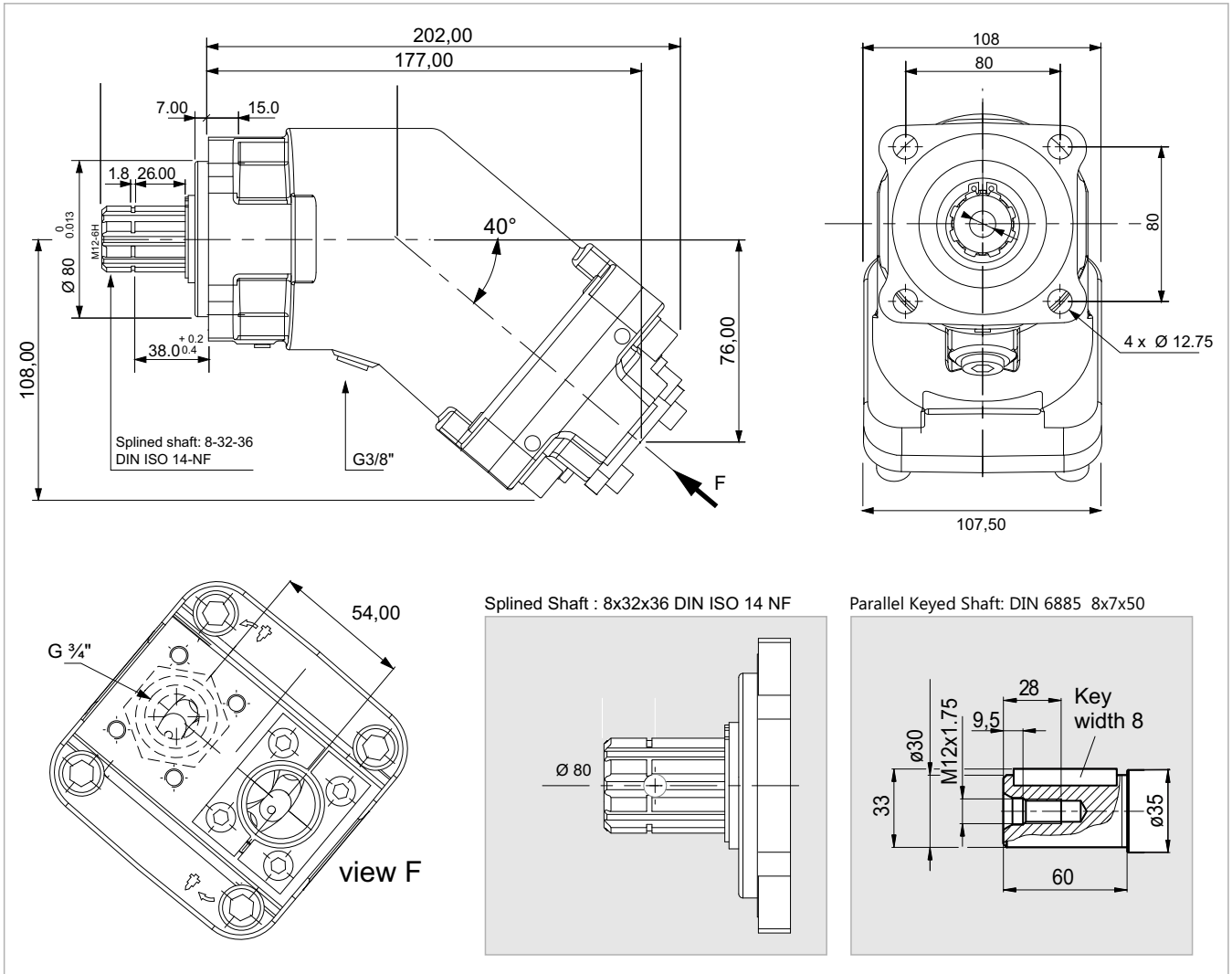

x 1000 rpm	32,00 cc
x 1500 rpm	48,00 cc
Max. Continuous Pump Speed	6250 rpm
Max. Intermittent Pump Speed	6800 rpm
Max. Continuous Pressure	400 bar
Max. Peak Pressure	450 bar
Torque bar	0.51 m.N/bar
Torque at 350 bar	174 m.N
Weight without accessories	11,00 kg
Weight with accessories	11,50 kg
Max. Motor Temperature	-25°
Min. Motor Temperature	110°

MD 40

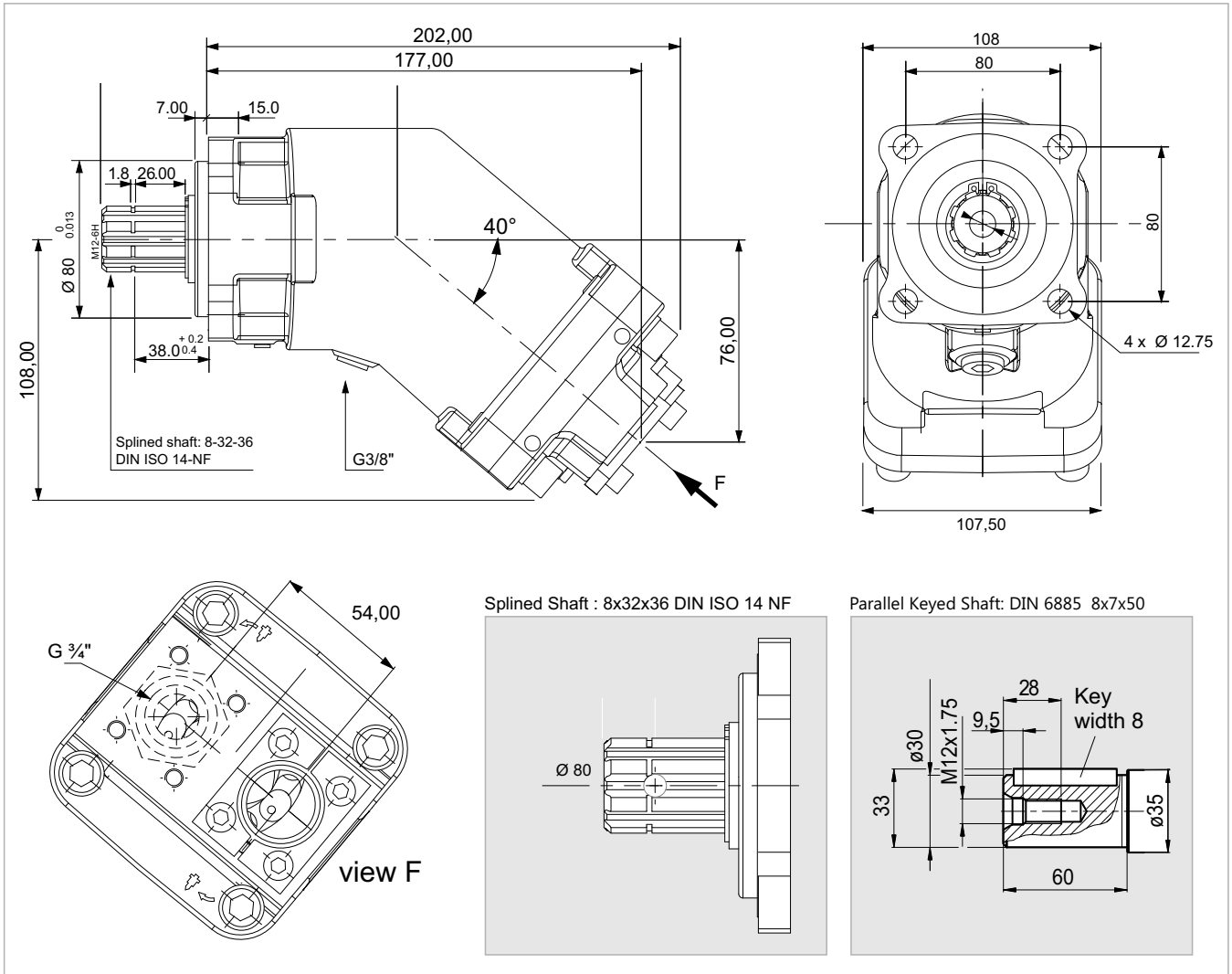

x 1000 rpm	40,20 cc
x 1500 rpm	60,30 cc
Max. Continuous Pump Speed	5600 rpm
Max. Intermittent Pump Speed	6300 rpm
Max. Continuous Pressure	400 bar
Max. Peak Pressure	450 bar
Torque bar	0.65 m.N/bar
Torque at 350 bar	228 m.N
Weight without accessories	11,00 kg
Weight with accessories	11,50 kg
Max. Motor Temperature	-25°
Min. Motor Temperature	110°

MD 50

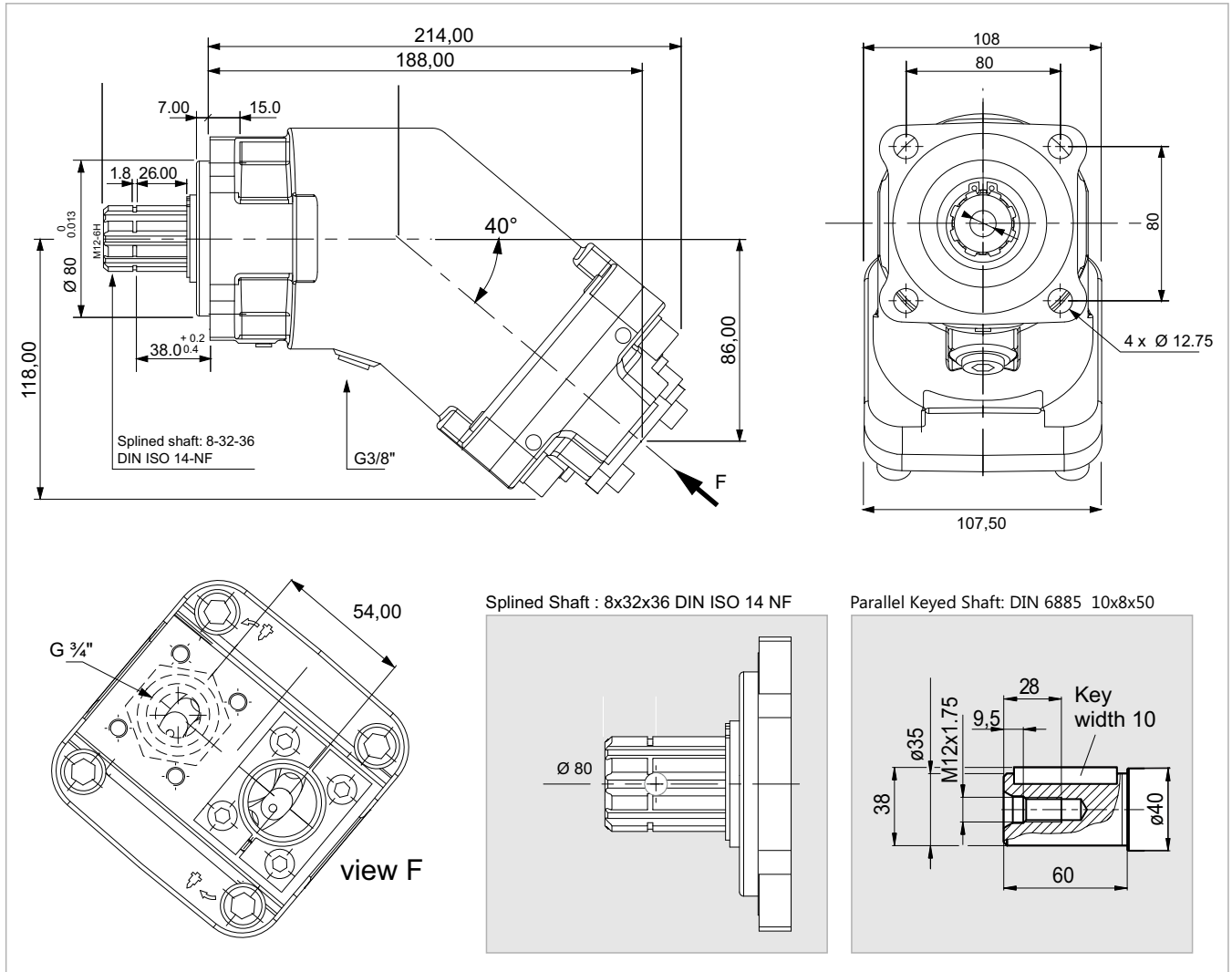

x 1000 rpm	50,00 cc
x 1500 rpm	75,00 cc
Max. Continuous Pump Speed	5000 rpm
Max. Intermittent Pump Speed	5500 rpm
Max. Continuous Pressure	400 bar
Max. Peak Pressure	450 bar
Torque bar	0.80 m.N/bar
Torque at 350 bar	280 m.N
Weight without accessories	11,00 kg
Weight with accessories	11,50 kg
Max. Motor Temperature	-25°
Min. Motor Temperature	110°

MD 56

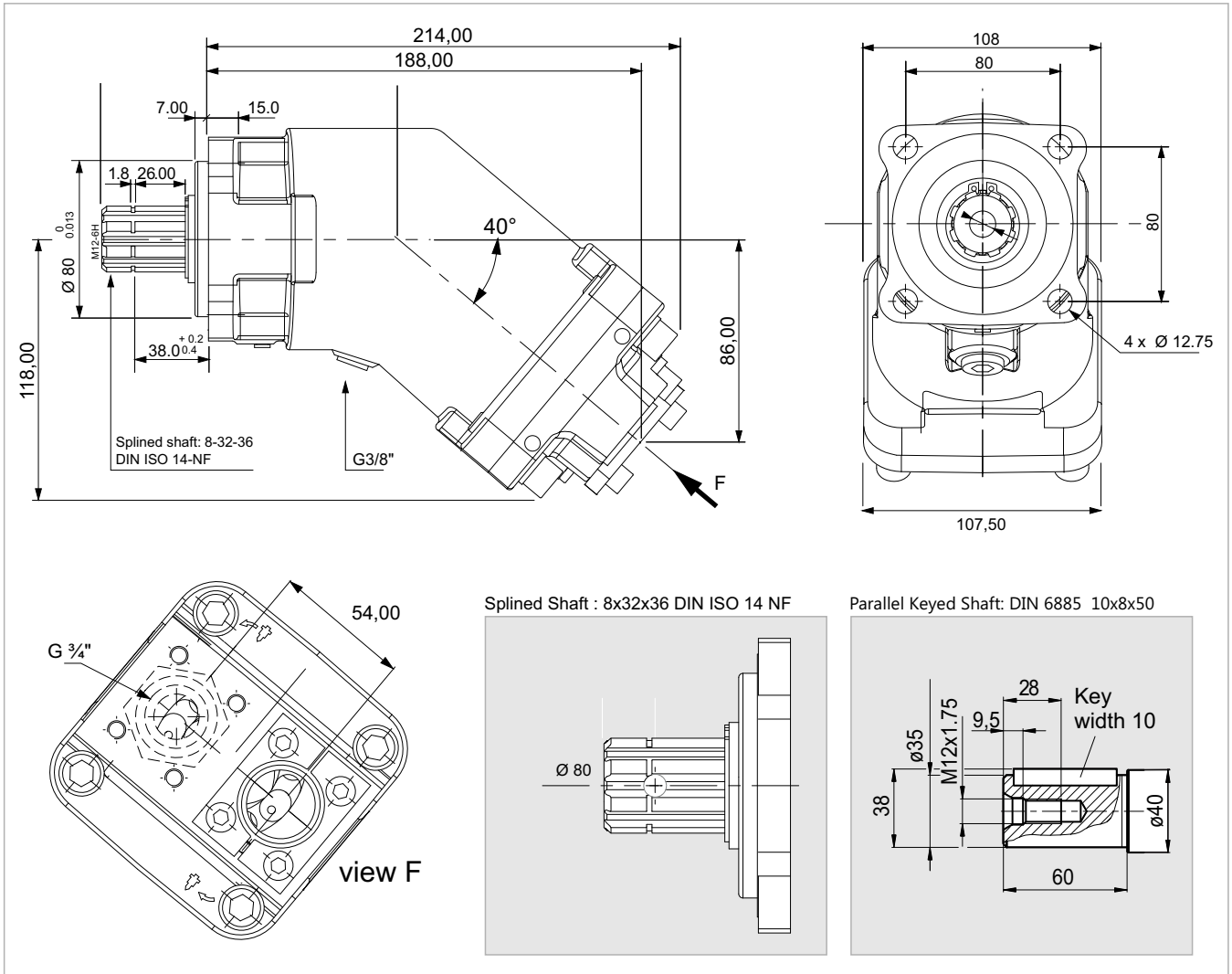

x 1000 rpm	56,40 cc
x 1500 rpm	84,60 cc
Max. Continuous Pump Speed	5000 rpm
Max. Intermittent Pump Speed	5500 rpm
Max. Continuous Pressure	400 bar
Max. Peak Pressure	450 bar
Torque bar	0.92 m.N/bar
Torque at 350 bar	320 m.N
Weight without accessories	12,00 kg
Weight with accessories	12,50 kg
Max. Motor Temperature	-25°
Min. Motor Temperature	110°

MD 63

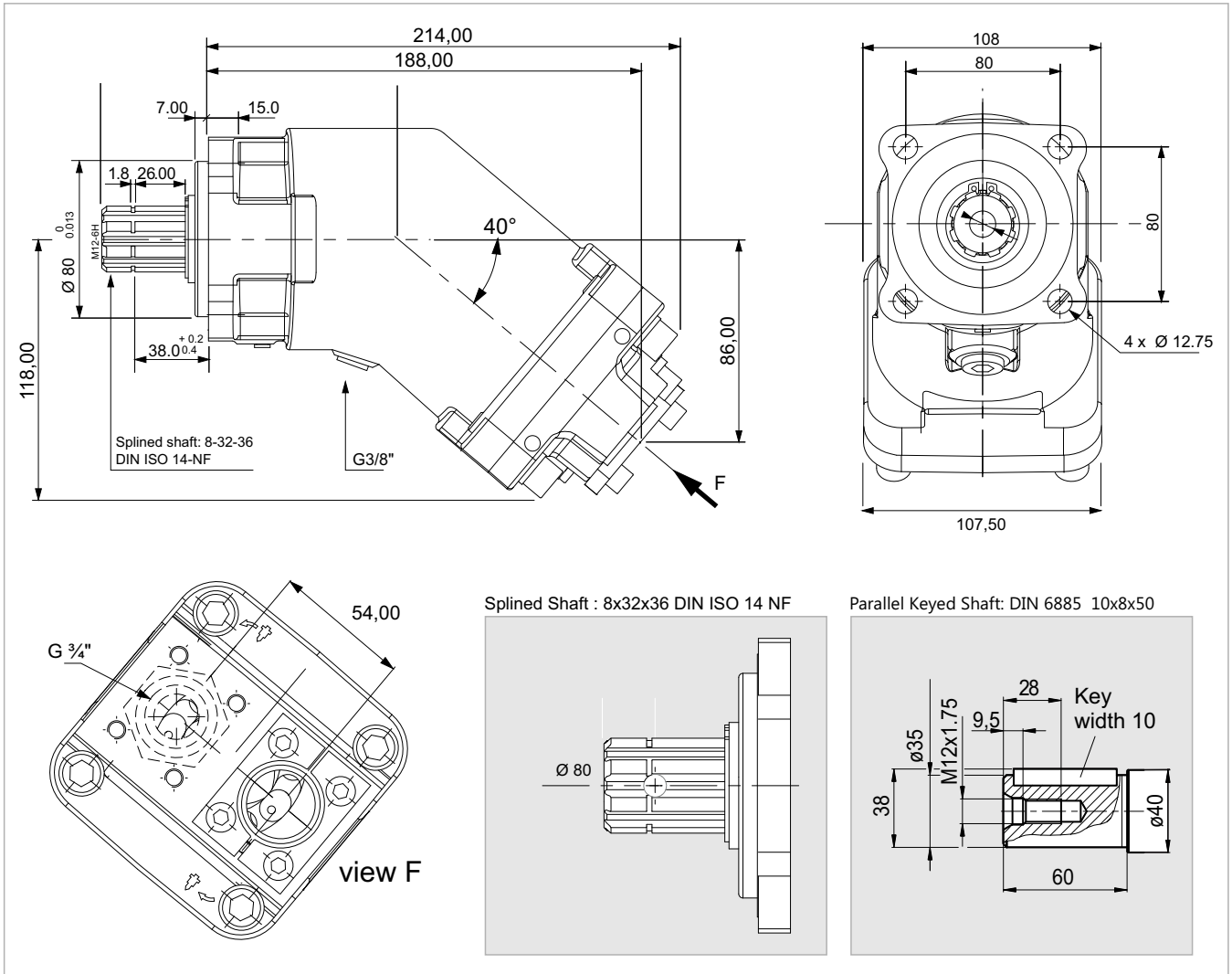

x 1000 rpm	63,00 cc
x 1500 rpm	94,50 cc
Max. Continuous Pump Speed	5000 rpm
Max. Intermittent Pump Speed	5500 rpm
Max. Continuous Pressure	400 bar
Max. Peak Pressure	450 bar
Torque bar	1.00 m.N/bar
Torque at 350 bar	350 m.N
Weight without accessories	12,00 kg
Weight with accessories	12,50 kg
Max. Motor Temperature	-25°
Min. Motor Temperature	110°

MD 80

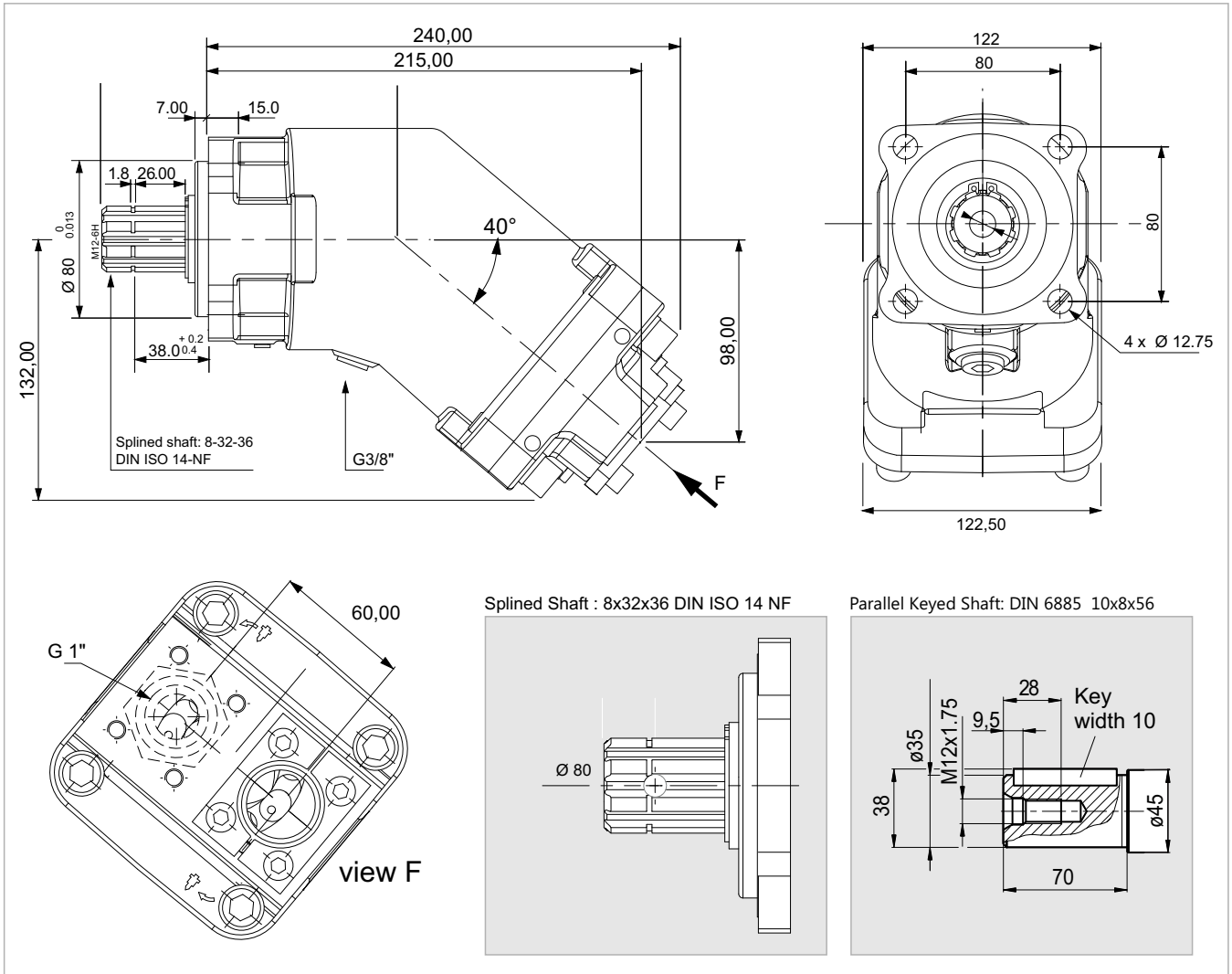

x 1000 rpm	80,00 cc
x 1500 rpm	120,00 cc
Max. Continuous Pump Speed	4400 rpm
Max. Intermittent Pump Speed	4900 rpm
Max. Continuous Pressure	400 bar
Max. Peak Pressure	450 bar
Torque bar	1.28 m.N/bar
Torque at 350 bar	440 m.N
Weight without accessories	15,00 kg
Weight with accessories	15,50 kg
Max. Motor Temperature	-25°
Min. Motor Temperature	110°

MD 108

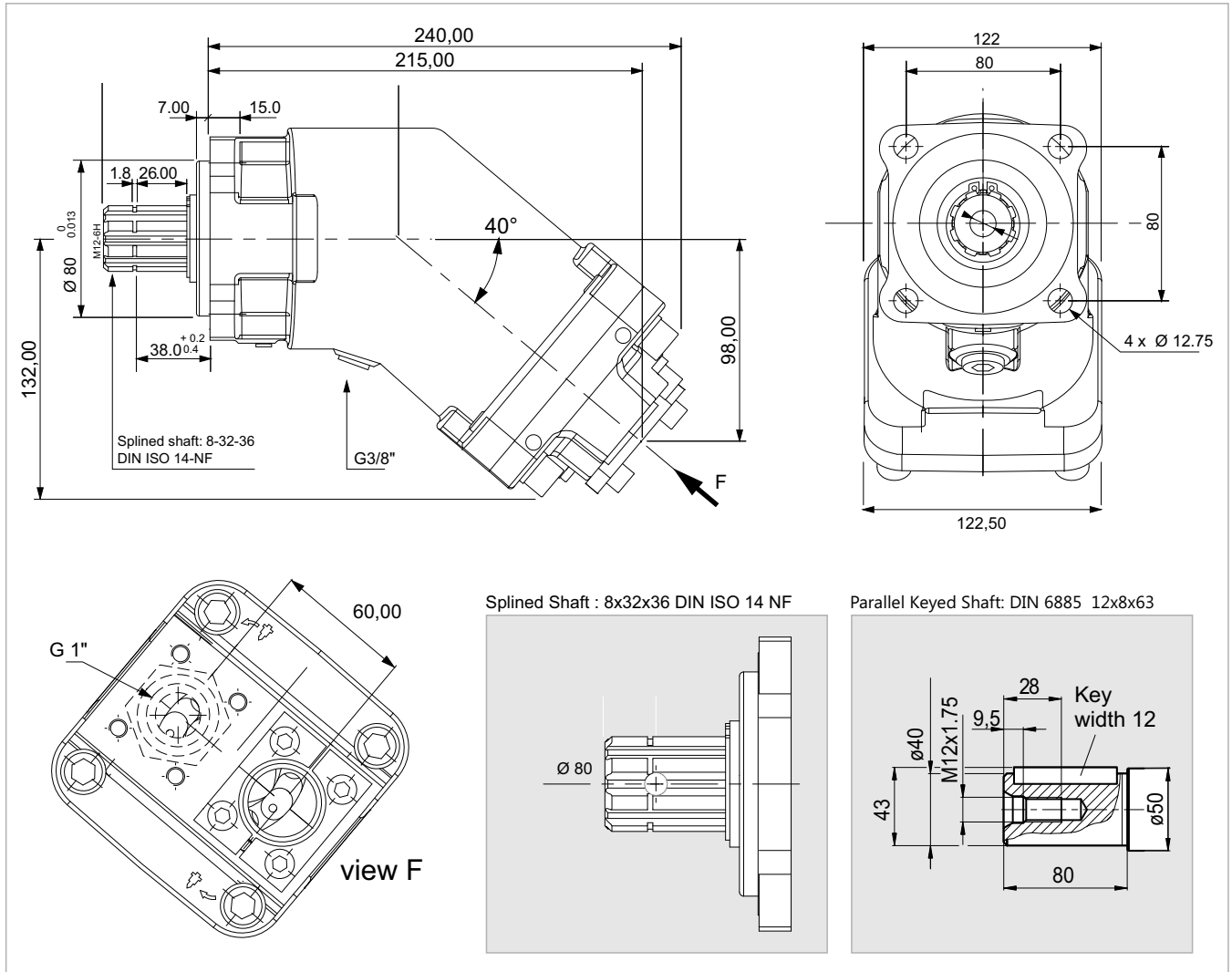

x 1000 rpm	108,40 cc
x 1500 rpm	162,60 cc
Max. Continuous Pump Speed	4000 rpm
Max. Intermittent Pump Speed	4400 rpm
Max. Continuous Pressure	400 bar
Max. Peak Pressure	450 bar
Torque bar	1.69 m.N/bar
Torque at 350 bar	600 m.N
Weight without accessories	16,00 kg
Weight with accessories	16,50 kg
Max. Motor Temperature	-25°
Min. Motor Temperature	110°

Direction of Rotation

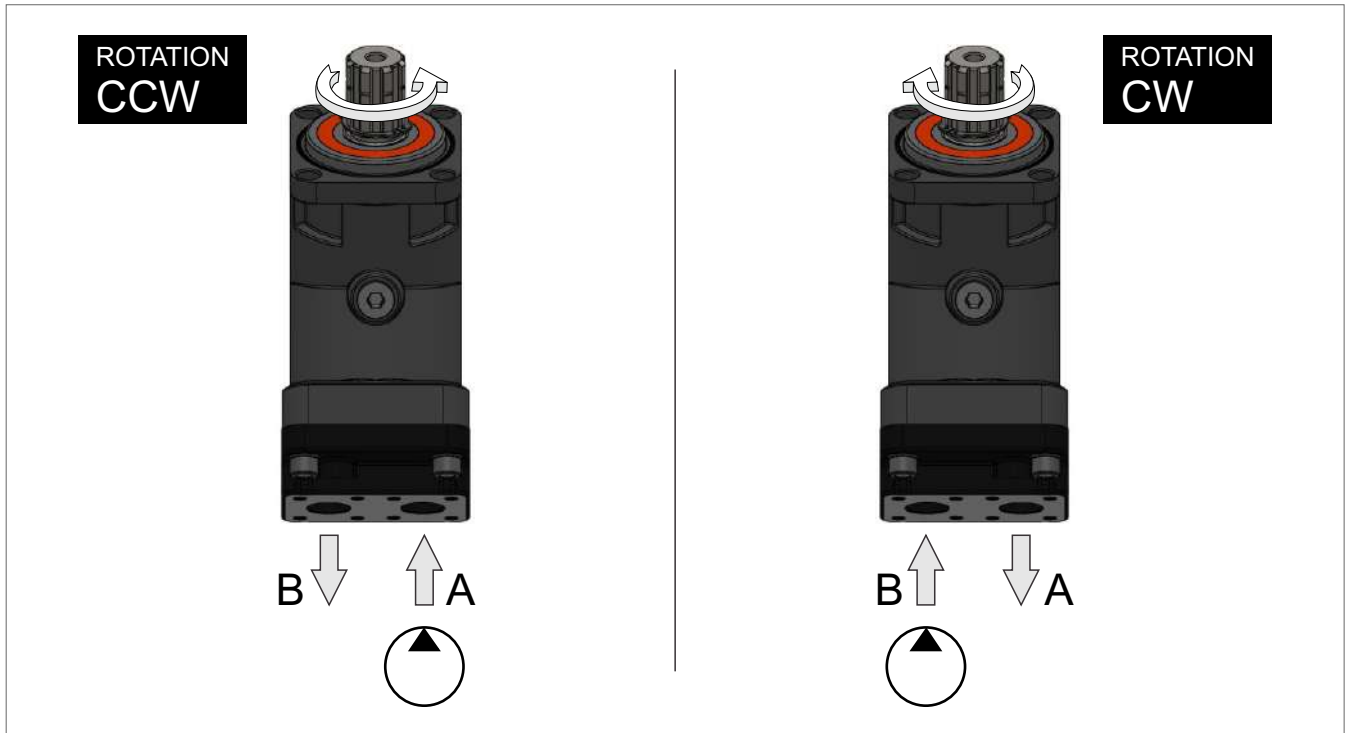

Quick Calculation

Flow rate

$$Q = \frac{V_s \cdot n}{1000 \eta_v} \text{ (lpm)}$$

Torque

$$M = \frac{V_s \cdot \Delta p \cdot \eta_{mh}}{63} \text{ (Nm)}$$

Power

$$P = \frac{2\pi \cdot M \cdot n}{60000} = \frac{M \cdot n}{9549} = \frac{Q \cdot \Delta p \cdot \eta_t}{600} \text{ (kw)}$$

Speed

$$n = \frac{1000 \cdot Q \cdot \eta_v}{V_s} \text{ (rpm)}$$

V_s = Displacement (ccm/rev.)

Δp = Diff. pressure (bar)

n = Speed (rpm)

Q = Flow (lpm)

η_v = Volumetric efficiency

η_{mh} = Mechanical-hydraulic efficiency

η_t = Total efficiency ($\eta_t = \eta_v \times \eta_{mh}$)

Address all questions regarding spare parts to your responsible Our Service Partner or the technical service department of the manufacture's plant / factory for the MD Bent Axis Motors.

Installation

POSITION

MD Motors can be operate any position.

DIRECTION OF ROTATION

MD Motors can be operate in both directions of rotation.

Before of Installation operation, the motor must be filled with hydraulic fluid and air bled.

INSTALLATION POSITION

See following examples.

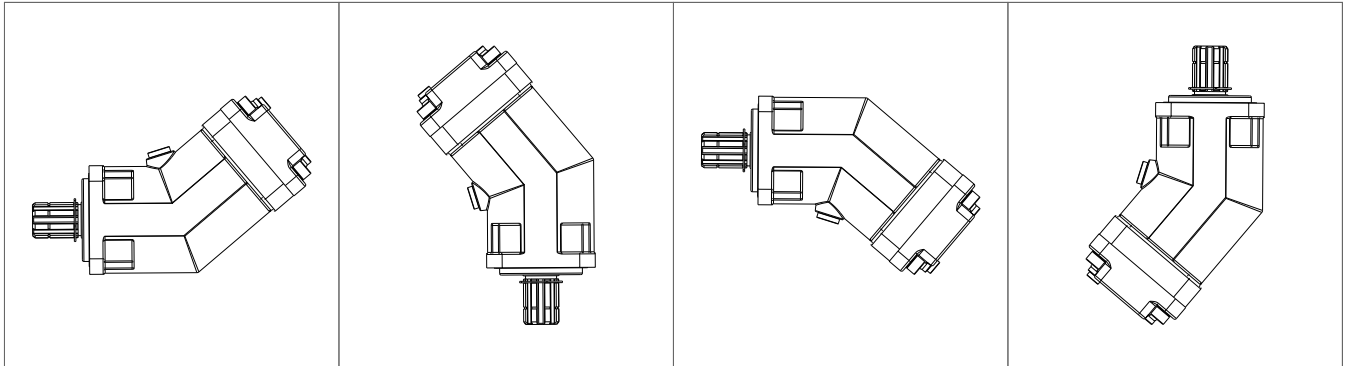

HYDRAULIC FLUID

Recommended ;

Generally : between 15 and 200 cSt.

Maximum : between 5 and 1600 cSt.

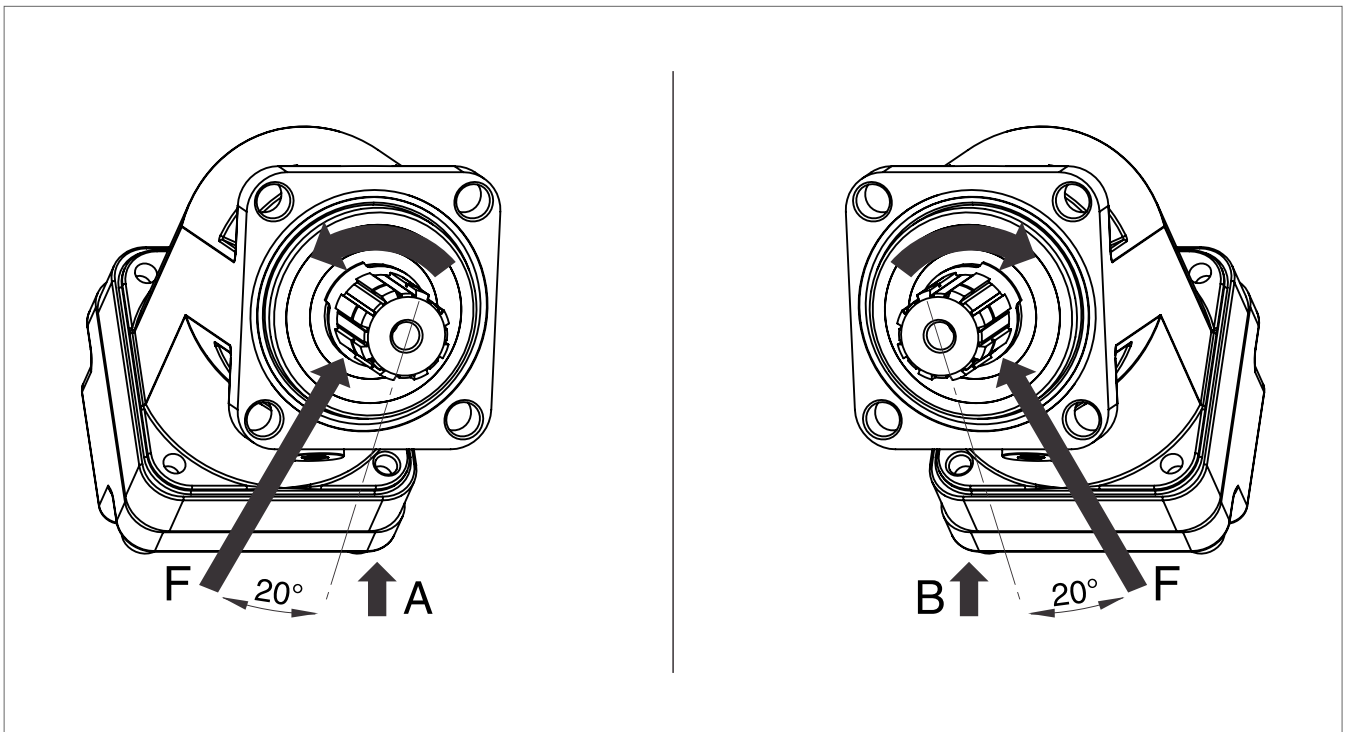

FOR USE;

Available via e-mail on request or each motor is supplied via Starting datasheet.

For detailed information about MD Bent Axis Motors, please contact with Technical Department !!!

SAFA

HYDRAULICS



PD-DIN
Bent Axis Pumps



MD-DIN
Bent Axis Motor



PA-SAE
Bent Axis Pumps



MA-SAE
Bent Axis Motor



PS-ISO
Bent Axis Pumps



MS-ISO
Bent Axis Motor



PD Dual
Dual Flow Pumps

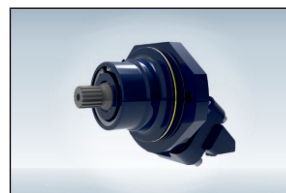

MF Fixed
Bent Axis Motor



PV
Variable Disp.
Piston Pumps

SAFA HYDRAULICS

ADDRESS:

Fevzi akmak Mahallesi 10465. Sk. Karatay | Konya / Turkey

TELEPHONE:

+90 332 342 10 21, +90 534 234 63 89, +90 539 592 71 71

FAX:

+90 332 342 45 71

E-MAIL:

info@safahydraulic.com

www.safahydraulic.com

In 6 Continents, 58 Countries Fevzi akmak Mh. 10465. Sk. Karatay +90 332 342 10 21

f t i l p

SAFA
HYDRAULICS

Home

About Us

Pumps & Motors

Catalogs

Applications

Quality

Contact Us

Q

CONTACT US

Home | Contact Us

Contact Us

Contact with SAFA Hydraulics



info@safahydraulic.com

www.safahydraulic.com